

# Custom Motion Systems

**Newport, Your High-Precision  
Motion Systems Solution Provider**

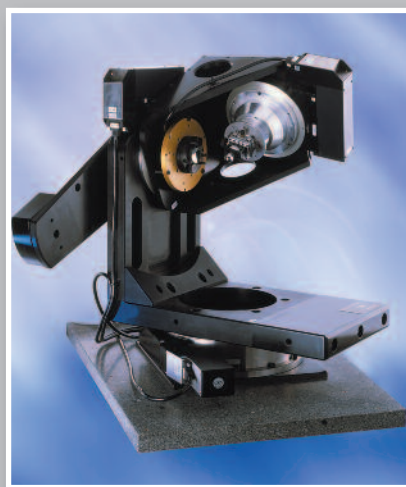

Advanced Solutions



Assemblies

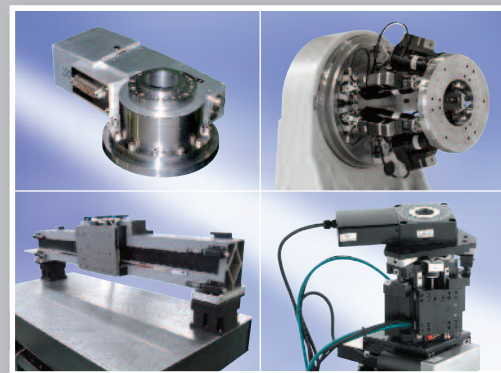

Technology Platforms

Precision Motion – **Guaranteed™**

 **Newport®**

Experience | Solutions

# Market-Leading Systems Solutions

From systems design through manufacture to on-site installation, Newport's motion system team is fully autonomous and focused on developing high precision custom systems solutions for research and industrial customers. As a world-class supplier of systems solutions, we'll bring you invaluable experience and expertise to match your needs exactly. To ensure your success, we are committed to the performance and quality levels of our solutions.

Our team has a combined experience with high precision, multi-axis motion component, design and manufacture that spans half a millennium. We offer a comprehensive understanding of customers' needs, through applications engineering, design, project management, manufacturing to customer operation excellence (Sales, CSR, Operations and Service).

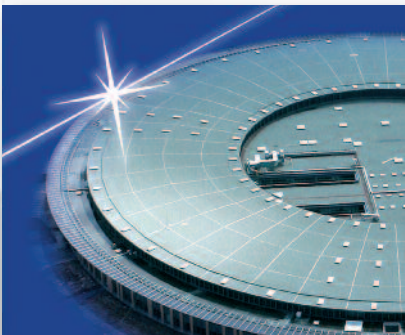

## MARKETS

Newport's custom systems serve a comprehensive range of markets:

- ▶ Industrial Metrology
- ▶ Industrial Micromachining
- ▶ Aerospace & Defense
- ▶ Research
- ▶ Semiconductor & Microelectronics
- ▶ Life Health Sciences

## APPLICATIONS

Call us for your systems requirements in:

- ▶ Positioning
- ▶ Test
- ▶ Metrology
- ▶ Inspection
- ▶ Manufacturing
- ▶ Advanced packaging
- ▶ Laser processing & micromachining

## TECHNOLOGIES

Newport's motion product offering includes many high precision technologies:

- ▶ Linear stages
- ▶ Rotary stages
- ▶ Goniometric stages
- ▶ High Load Actuators
- ▶ DC/Stepper/Piezo and linear motors
- ▶ Integrated motion controller to 12 axis
- ▶ Material Preparation
- ▶ Vacuum Preparation
- ▶ Ceramic Structures (SIC)

# Systems Solutions to Perfectly Match your Needs

From technology platforms to assemblies and advanced solutions, we constantly focus all our efforts to deliver high performance systems to our customers at the right price. With Newport, you can rely on an experienced partner to analyze the feasibility of your project and to support you throughout the lifetime of your custom solution.

## 1. TECHNOLOGY PLATFORMS

These technology platforms represent a broad product offering that is differentiated from our standard product by their very advanced technology features. These offer an excellent return on investment for industrial customers looking for answers to their demanding problems with the benefits of using already proven products and technologies. Our automated solutions can help achieve yield, productivity and performance improvements and to cut down on production costs.

- ▶ Advanced products (higher speed, higher loads, long travel, higher resolution and sensitivity)
- ▶ Advanced Motion Electronics and Algorithms
- ▶ Material and Environmental Preparation
- ▶ Custom interfaces
- ▶ Air bearing stages
- ▶ Ceramic Structures (SiC)

### Motorized Actuators



- ▶ Vertical actuator using an RV120 rotary stage and a screw, 250 kg load capacity, with V6 vacuum preparation.
- ▶ Up to 500 kg load capacity, high stiffness with 0.5  $\mu\text{m}$  sensitivity.

### Hexapods



6 DOF hexapods, up to 1400mm and 400kg loads ▶

### Rotation Stages

**High Torque and High Load Capacity**



▶ The RVU500 moves a Hexapod holding a heavy cantilevered payload.

**High Sensitivity and High Angular Stiffness**

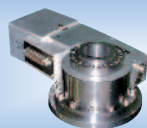

▶ A RVU80V6 used in the kinematic chain of a large mirror mount.

**High Sensitivity and High Angular Stiffness**

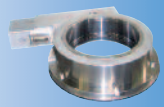

▶ The RVU240 used in an azimuth/elevation mirror mount.

### Long Travel Linear Stages

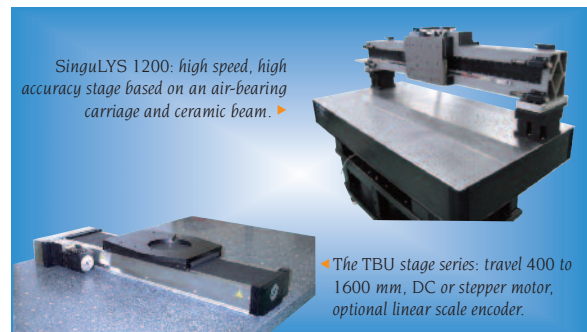

SinguLYS 1200: high speed, high accuracy stage based on an air-bearing carriage and ceramic beam. ▶

▶ The TBU stage series: travel 400 to 1600 mm, DC or stepper motor, optional linear scale encoder.

### High Resolution Z-Stages



▶ Compact, high resolution Z-Tip-Tilt stage.

Vertical linear stage with backlash-free ballscrew, 20 kg load capacity, steel construction, 10 nm sensitivity. ▶

## Environmental Preparation

For applications requiring special environmental preparation, you can depend on Newport's extensive product lines and vast application experience. Over the years, we have mastered the small, but critical details necessary to operate in these special environments:

- ▶ Clean room
- ▶ High or low temperature environments
- ▶ Vacuum:  $10^{-3}$  hPa ( $7.5 \times 10^{-4}$  Torr)
- ▶ High Vacuum:  $10^{-6}$  hPa ( $7.5 \times 10^{-7}$  Torr)
- ▶ Ultra High Vacuum:  $10^{-9}$  hPa ( $7.5 \times 10^{-10}$  Torr)
- ▶ Non magnetic and High energy
- ▶ EUV



We have delivered countless solutions to research, semiconductor, military and aerospace customers looking for the best combination of ultra high precision motion and environmental preparation

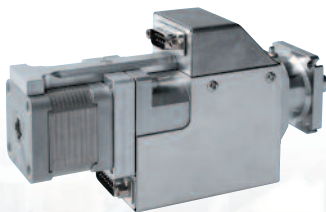

▲ Up to 30 mm travel, 50 kg load capacity, 50 nm resolution, high level of cleanliness.

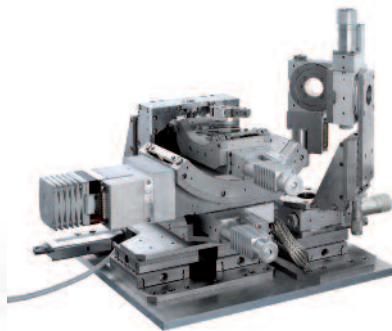

▲ Vacuum compatible target positioning sub-assembly.

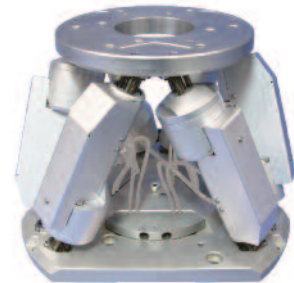

▲ Vacuum compatible hexapod, HXP50V6.

Preparation for these types of challenging environments requires a deep understanding of material science, as each level of specification will drive its own set of allowable materials. We typically modify our standard products that consider the compatibility of grease or lubricants, cable insulators, motors, electronics like limits or origin switches, hardware (material and purge holes), surface finishes (no anodization) and materials (porosity). Accompanying these special material considerations, are manufacturing processes and facilities specifically developed to ensure the highest level of control of product performance.

At Newport we believe in providing you with the most options possible to address your need for motion products in special environments. This is why our team introduced a few standard products that are vacuum and clean room compatible and are available in stock or within a short leadtime. For other environments listed above, we will work together with you to customize the right Motion solution.

## 2. ASSEMBLIES

These are economical solutions devised from Newport's standard motion catalog products. Our application experts will help you in selecting the best combination of products to fit your exact need. We add value by optimizing the performance level of these components to your requirements, committing ourselves to the global specifications of the system by performing metrology before delivery, as required.

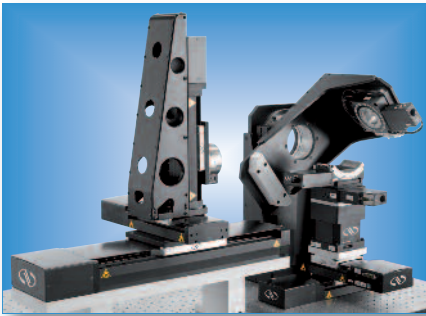

▲ 11-axis bench for the calibration of on-vehicle safety sensors in the automotive industry.



▲ 150 kg rangefinder calibration gimbal.



▲ Antenna and sensor positioner to measure signals in 3D for guidance and field communication systems.

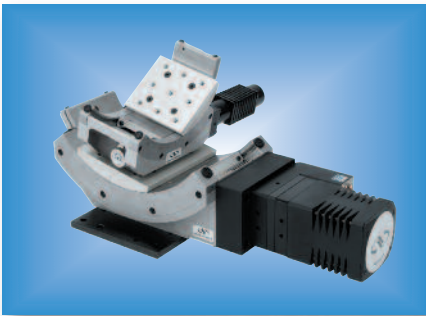

▲ These nested goniometric cradles can be aligned to provide a 100  $\mu$ m sphere of confusion about the point of rotation.

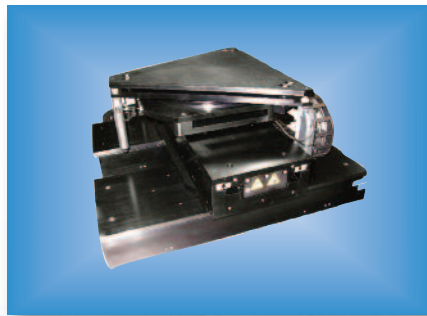

▲ A custom 5 axes motion system XYZ with Tip and Tilt.

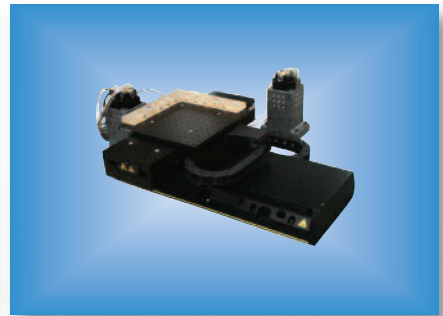

▲ An IDL Series XY stack with interferometer feedback .



▲ Aircraft sensor test gimbal.



▲ Position sensing detector test station.



▲ 4-Axis sensor calibration assembly.

### 3. ADVANCED SOLUTIONS

Leveraging decades of experience and expertise in precision motion engineering, Newport's advanced solutions are designed to solve complex motion problems and deliver long-lasting high precision performance in critical applications. These fully integrated, multi-axis, turnkey custom systems represent the pinnacle of Newport's system design capabilities and incorporate many innovative technologies such as air bearing platforms, ceramic materials and advanced control electronics. Backed by a dedicated team of systems engineers, our advanced systems are built to bring the competitive edge to the customer.

#### Multi-Axis, Turnkey for Metrology Testing and Positioning Applications

Newport's advanced systems serve in such areas as system development, metrology and testing applications at leading manufacturing companies and R & D centers around the globe, making Newport the worldwide leader in advanced precision systems engineering.



◀ *Sample positioner:*  
2-ton sample positioner for Neutron synchrotron.

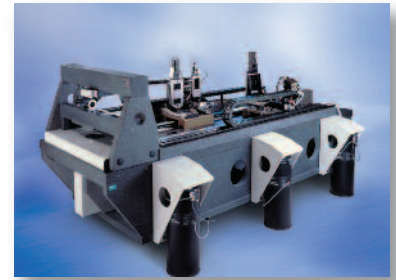

*Air-bearing system:*  
This system was designed for large-scale assembly and testing of optics. The multi-axis system features a very rigid silicon carbide and granite structure for superior stability and flatness, 19 motorized axes for alignment and positioning and 2 long travel air-bearing stages driven by linear motors. ▶



◀ *Newport designs and manufactures motorized mirror mounts for high power laser facilities. These mounts accommodate a variety of large optics for laser beams up to 600 mm diameter in very demanding environmental conditions (cleanliness, vacuum).*



*6-axis sample stage:*  
A compact, fully integrated stage including 3 translations and 3 rotations for the positioning and orientation of loads up to 150 kg. The sphere of confusion of the 3 rotation axes is 25  $\mu\text{m}$ . ▶



▲ *12 axis motion system for twin fiber alignment.*

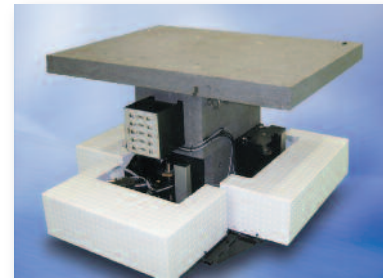

▲ *LB Leveling base:*  
High precision 5-axis heavy motorized base used for leveling and positioning a complete optical system. Tripod system, vertical range  $\pm 100$  mm, tilt  $\pm 2.5^\circ$ . 3000 kg centered load capacity. Optional air-bearing kit.

### Multi-axis Custom Systems for Diffractometry

Newport's expertise in the design of advanced diffractometry solutions for synchrotrons is second to none. With Newport, you can rely on a partner that has tremendous technical knowledge and experience to perfectly understand your requirement and design the right solution for your application. Newport's diffractometers are used to measure the surface, interface and thin film diffraction of materials.

Today, Newport has an installed base of over 30 diffractometers in labs and latest generation synchrotrons all over the world. These solutions serve fundamental and applied research in such areas as life health sciences, physics and materials sciences.

Diffractometer: 4-circle Multi-Purpose Diffractometer. ▶



◀ N6050 Cross K1 X-Ray Diffractometer: 6-Circle Multi-Purpose Goniometer.



◀ X-ray diffractometers are full custom and turnkey systems used to study the structure and properties of materials. Over 30 diffractometer systems in synchrotrons all over the world serve the scientific community in a large variety of application fields.

Multi-axis X-Ray diffractometer used by scientists in a synchrotron facility for a variety of diffraction-based applications. ▶



▶ 4-Circle Diffractometer for Crystallography

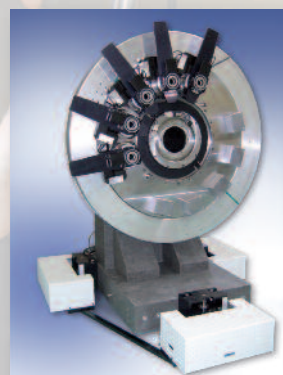

▶ 3-Circle Powder Diffractometer.

## Capabilities

Newport offers a wide choice of high precision equipment for numerous diffractometry applications carried out at synchrotron beam lines.

Reference number	Instrument	Application
N6050 Cross K1	6-circle multi purpose kappa goniometers	Multi-technic diffraction
N4050	4-circle vertical kappa Goniometer	Crystallography, proteins
N3050 P1	3-circle goniometer	Powder diffraction
N2020	2-circle goniometer	Versatile, analyzer
N2020 Pol	3-circle goniometer	Versatile, analyzer
N4050 CCD	4-circle turn-key vertical kappa diffractometer	Crystallography, proteins
N2020 Mac	2-circle high resolution goniometer for multi-strip analyzer	Powder diffraction
XPS-C8	XPS 8 axis motion controller/driver	Tango and Epics driver
LB150	3, 4 and 5 axis high accuracy leveling base for X-ray heavy instrumentation	
IS4CCD	Crystallography software package Anti collision software for the N4050	Crystallography and others

## Advanced Motion Control Solutions

Newport's multi-axis diffractometry systems are operated by advanced control electronics, all built in-house for optimal performance of the system. Our proprietary technologies come from 50 years of experience in motion control. Our control electronics and software offer unmatched precision and reliability, and are backed by a service warranty and technical support. We also offer a wide range of motorized linear and rotation stages that can be used as positioners for detection equipment.

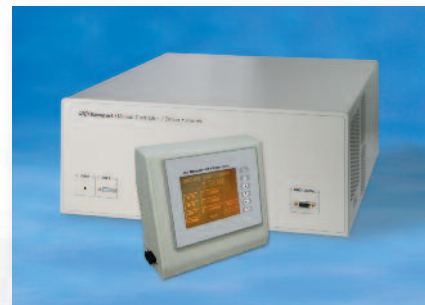

### Anti-Collision Software

Need to simulate a motion trajectory? Newport's proprietary anti-collision software is a powerful tool for simulating the motion of detection equipment and determining optimal trajectories for their positioning. In that way, collisions and costly damages to your equipment are avoided. The motion simulation is done on the fly using the 3D CAD files generated during the study of the goniometer.

### Detection Equipment

In addition to high precision positioning equipment, Newport together with its partners are able to provide you with a variety of high-performance detectors for your research application. Today, Newport has a preferred non exclusive partnership with Oxford Diffraction Ltd.

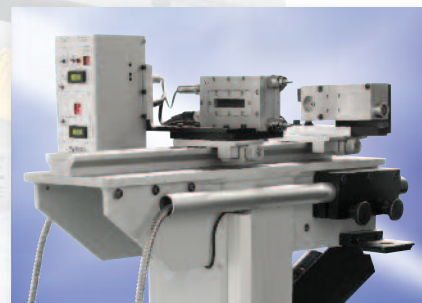



# Comprehensive Design & Engineering Resources

## DESIGN & ENGINEERING

Our application engineers and designers will assist you to conceptualize your system through in-depth technical discussion and analysis. They can collaborate very closely with your engineering team to design the best solution for you and provide a wide range of services:

*Our engineering team can help the customer with a solution definition. These capabilities can be split into two categories, design/application engineering and project management.*

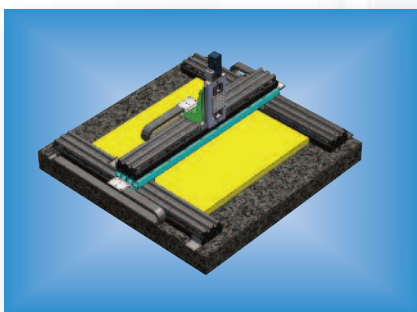

▲ Gantry XY, long travel.

- ▶ Drawings
- ▶ Design analysis and modeling
  - Solidworks
  - Ansys
  - Matlab
- ▶ Design from concept
- ▶ Risk and failure analysis
- ▶ Documentation

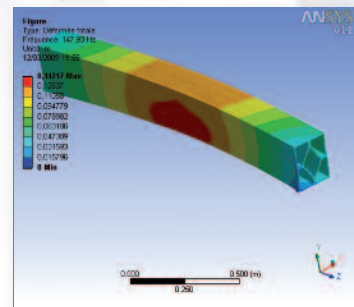

▲ SiC ceramic beam simulation.

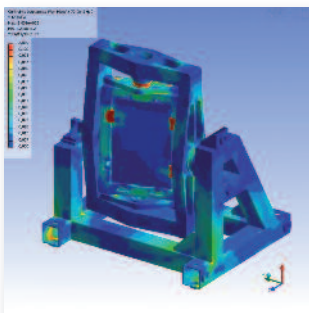

◀ Mirror mount stress analysis.



## PROJECT MANAGEMENT

The project management process below is typically implemented and is modified depending on the type of project.

- ▶ Requirements analysis
- ▶ Feasibility review
- ▶ Statement of work
- ▶ Value analysis
- ▶ Design analysis and modeling
- ▶ Production and metrology
- ▶ Test
- ▶ Installation and on-site inspection
- ▶ Training

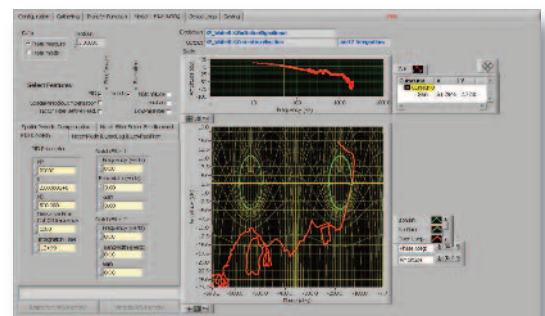

▲ Advanced XPS motion control tools.

# Metrology and Acceptance Test Procedure

Extensive metrology capabilities and resources are used to test, analyze and measure critical system specifications to achieve excellence in quality, precision and performance. The best available metrology tools are used to provide customers with real performance data.

## 5 LEVELS OF METROLOGY

Depending on your need, the Newport technical team can propose 5 distinct and complementary levels of metrology with your custom motion solution. We will provide calibration data with our advanced products clearly stating the guaranteed specifications. At Newport we want to make sure that we deliver on our promises and that your purchase will perform exactly as you expect it.

In case of an Assembly, we will demonstrate system performance. This performance can be demonstrated using two complementary methods. The first one is called Global Accuracy measurement and it consists of metrology performed on a combination of multiple linear and rotation axes that can be measured as a group. There are limitations to this method due to the availability of metrology systems and is augmented with a secondary method that consists of

a theoretical error analysis for stack up of tolerances for the remaining axis that could not physically be measured as part of the group. The use of both methods has demonstrated, in our extensive systems experience, to be an excellent gauge of the quality of the performance of the completed system.

For very demanding applications we can also perform dynamic performance verification as well as single or multi axis error mapping.

We will work with you to put in place a metrology plan that is tailored to your needs and will ensure that it is representative of your application. We can use simulated loads, measure performance at the point of interest on assembled sub-systems, following your system's motion range.

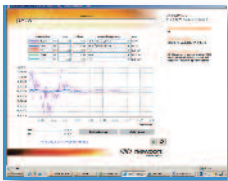

▲ XY calibration using interferometer.

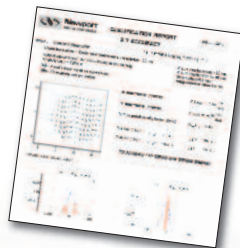

▲ Multi-axis SOC using autocollimator.



## QUALITY CONTROL

At Newport, we provide quality control services and can customize these to account for your specific environment. Newport continuously maintains its ISO9001.2008 registration.

### METROLOGY TOOLS

- ▶ Interferometers
- ▶ Autocollimators
- ▶ Modal tests systems
- ▶ Environmental chambers
- ▶ Very high precision encoders
- ▶ Temperature controlled metrology room
- ▶ Real time acquisition
- ▶ Vibration isolated platform

### ADDITIONAL CUSTOMER SERVICES

- ▶ On-site installation
- ▶ Metrology services both at factory and customer sites
- ▶ Maintenance contracts
- ▶ Training
- ▶ After sales services
- ▶ Documentation

# World-Class Capabilities

Newport's motion systems are manufactured in world-class facilities in France and in the US, to the latest ISO standards. Customer visits can be readily organized by our staff for on-site evaluation, demonstrations, acceptance and testing. State of the art manufacturing technologies, world-class operations, staff and logistics, enable us to adapt quickly to changing customer and market requirements and to get new motion products and systems designed, produced, and delivered very efficiently.



## Other Related Brochures

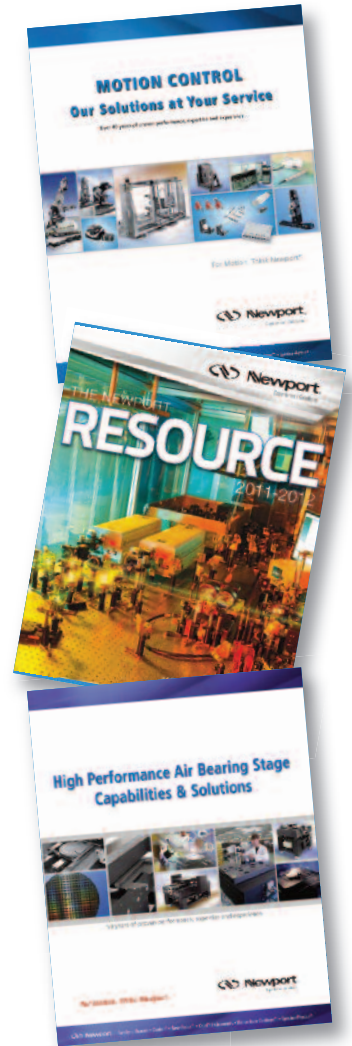

# Global Service

From on-site installation to field and factory service capabilities Newport offers a broad palette of customer services at the global level, we have a dedicated team of engineers and technicians to support the installed base. Our global infrastructure means, wherever you are, and whatever you want, we can help!



[www.newport.com](http://www.newport.com)

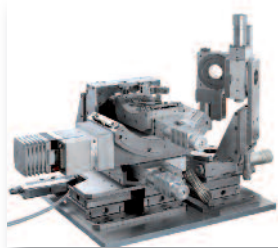

 **New Focus™**  
A Newport Corporation Brand

 **DRIEL  
INSTRUMENTS**  
A Newport Corporation Brand

 **Richardson Gratings™**  
A Newport Corporation Brand

 **Spectra-Physics.**  
A Newport Corporation Brand

 **Newport.**  
Experience | Solutions

**Newport Corporation, Global Headquarters**  
1791 Deere Avenue, Irvine, CA 92606, USA

[www.newport.com](http://www.newport.com)

**PHONE:** 1-800-222-6440 1-949-863-3144 **FAX:** 1-949-253-1680 **EMAIL:** [sales@newport.com](mailto:sales@newport.com)  
Complete listings for all global office locations are available online at [www.newport.com/contact](http://www.newport.com/contact)

	PHONE
Belgium	+32-(0)0800-11 257
China	+86-10-6267-0065
France	+33-(0)1-60-91-68-68
Japan	+81-3-3794-5511
Taiwan	+886 -(0)2-2508-4977

EMAIL
<a href="mailto:belgium@newport.com">belgium@newport.com</a>
<a href="mailto:china@newport.com">china@newport.com</a>
<a href="mailto:france@newport.com">france@newport.com</a>
<a href="mailto:spectra-physics@splasers.co.jp">spectra-physics@splasers.co.jp</a>
<a href="mailto:sales@newport.com.tw">sales@newport.com.tw</a>

	PHONE
Irvine, CA, USA	+1-800-222-6440
Netherlands	+31-(0)30 6592111
United Kingdom	+44-1235-432-710
Germany / Austria / Switzerland	+49-(0)6151-708-0

EMAIL
<a href="mailto:sales@newport.com">sales@newport.com</a>
<a href="mailto:netherlands@newport.com">netherlands@newport.com</a>
<a href="mailto:uk@newport.com">uk@newport.com</a>
<a href="mailto:germany@newport.com">germany@newport.com</a>